

ILUM

Kamerton



NATURE OF LIGHT

Kamerton

Suspended

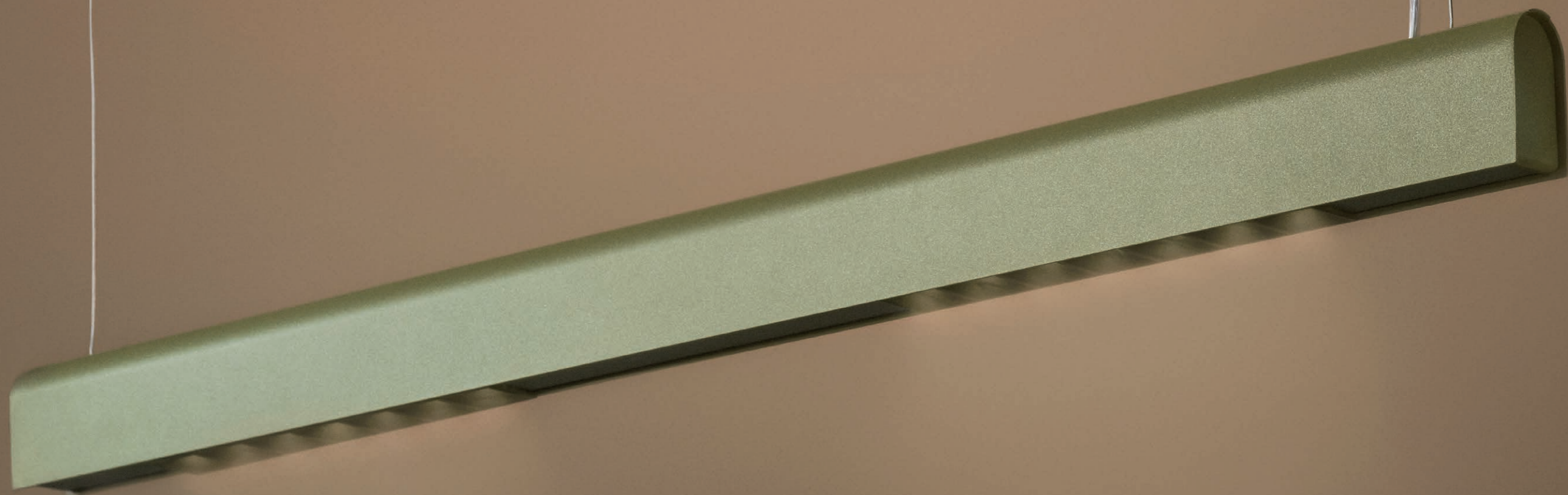

Kamerton 1100 S Louver

Prostota z charakterem

Lampa została zainspirowana kształtem kamertonu, który jest przyrządem używanym do strojenia instrumentów muzycznych. Prosty, delikatny i zaoblony kształt aluminiowej oprawy stanowi podstawowy element w kreowaniu przestrzeni za pomocą światła.

Simplicity with Character

The lamp was inspired by the shape of a tuning fork, which is a tool used for tuning musical instruments. The simple, delicate, and rounded shape of the aluminum fixture is a fundamental element in creating space through light.

Schlichtheit mit Charakter

Die Leuchte wurde von der Form einer Stimmgabel inspiriert, einem Werkzeug, das zur Stimmung von Musikinstrumenten verwendet wird. Die schlichte, abgerundete Form des Aluminiumgehäuses ist ein grundlegendes gestaltendes Element der Lichtinstallation.

Kamerton

Collection

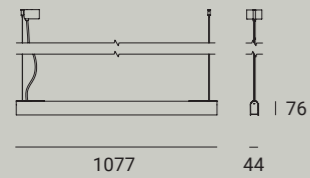

Kamerton
1100 S

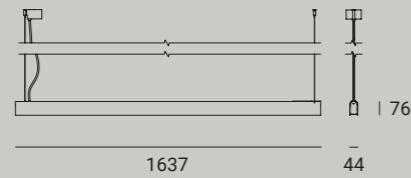

Kamerton
1600 S

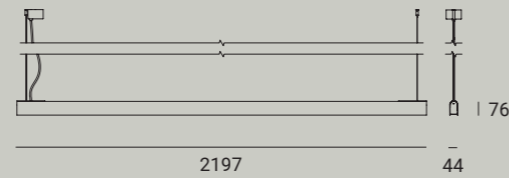

Kamerton
2200 S

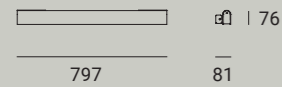

Kamerton
800 W

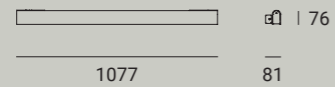

Kamerton
1100 W

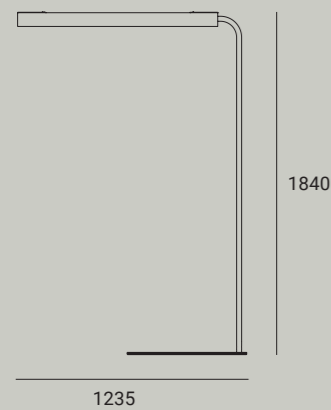

Kamerton
Stand

Kreowanie światłem

Rodzina Kamerton to doskonałe narzędzie do integracji elementu światła z przestrzenią. Każda z lamp oświetla dwie przeciwstawne strony, zapewniając optymalne oświetlenie całego pomieszczenia. Aluminiowe oprawy o różnych kolorach i rozmiarach nadadzą charakter każdej przestrzeni, niezależnie od tego, czy jest to małe biuro czy przestronny dom. Kolekcję uzupełnia także kinkiet, który dedykowany jest do korytarzy i wąskich przestrzeni.

Creating with Light

The Kamerton family is an excellent tool for integrating the element of light with space. Each lamp illuminates two opposing sides, providing optimal lighting for the entire room. Aluminum fixtures in various colors and sizes will give character to any space, whether it's a small office or a spacious home. The collection is complemented by a wall sconce, which is dedicated to corridors and narrow spaces.

Erschaffen mit Licht

Die Kamerton-Familie ist ein hervorragendes Werkzeug, um das Element des Lichts mit dem Raum zu vereinen. Durch die direkte und indirekte Abstrahlung wird eine optimale Beleuchtung des gesamten Raums ermöglicht. Die verschiedenen Farben und Größen der Kamerton-Leuchte verleihen jedem Raum Charakter, egal ob es sich um ein kleines Büro oder ein geräumiges Zuhause handelt. Die Kollektion wird durch eine Wandleuchte ergänzt, die für Flure und schmale Räume bestimmt ist.

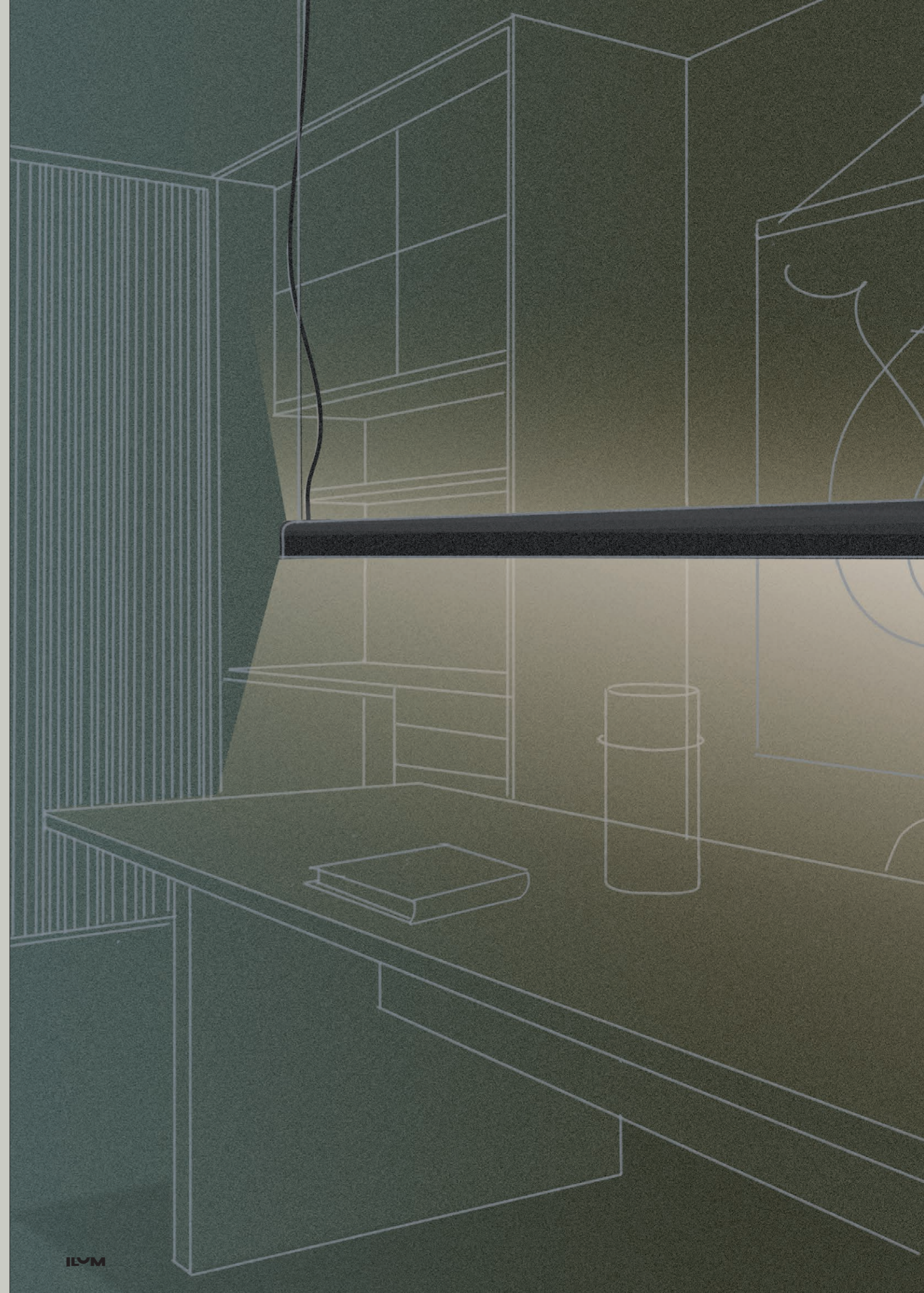



Kamerton

Collection

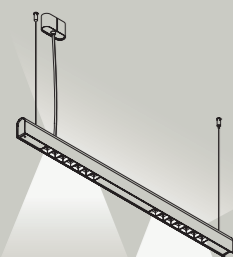

Kamerton
1100 S Louver

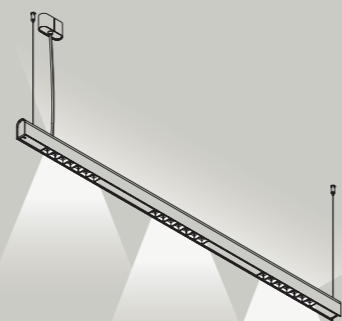

Kamerton
1600 S Louver

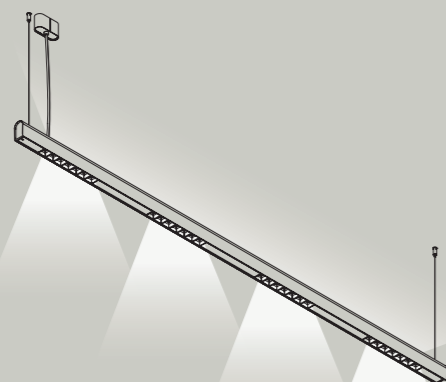

Kamerton
2200 S Louver

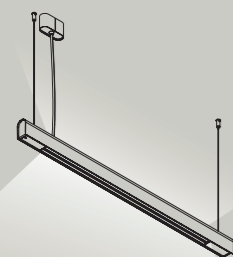

Kamerton
1100 S Line

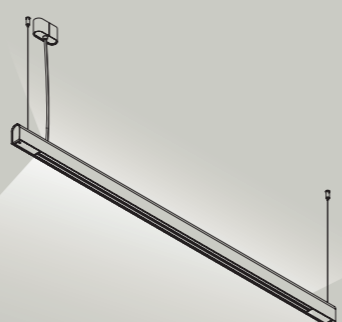

Kamerton
1600 S Line

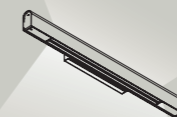
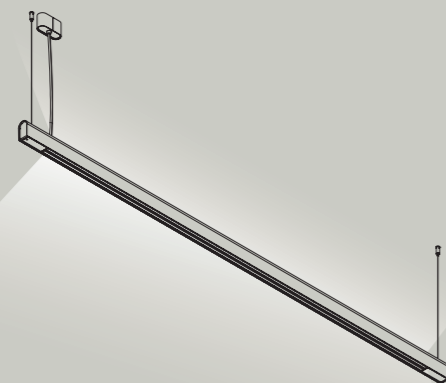

Kamerton
800 W Line



Kamerton
1100 W Line

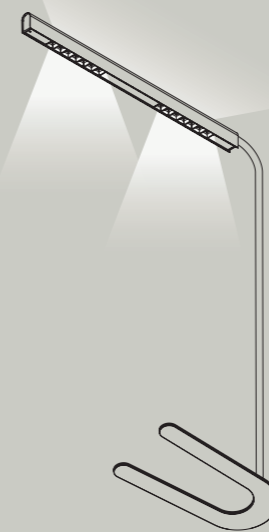

Kamerton
Stand Louver



Kamerton
Stand Line

Narzędzie w projektowaniu

Dzięki szerokiemu wyborowi rozmiarów, kolorów oraz źródeł światła, rodzina Kamerton to doskonałe rozwiązanie do swobodnego kreowania przestrzeni światłem. Produkt dedykowany zarówno na rynek kontraktowy, jak i domowy. Lampa doskonale oświetli zarówno stół w jadalni, jak i biuro na otwartym planie. Dzięki wachlarzowi możliwości adaptacji produktu, użytkownik może dostosować lampę do swoich potrzeb.

A Design Tool

Thanks to a wide selection of sizes, colors, and light sources, the Kamerton family is an excellent solution for freely creating spaces with light. The product is suitable for both the contract market and residential use. The lamp will perfectly illuminate both the dining table and an open-plan office. With a range of customization options, users can adapt the lamp to their needs.

Ein Werkzeug im Design

Dank einer breiten Auswahl an Größen, Farben und Lichtquellen ist die Kamerton-Familie eine ausgezeichnete Lösung, um Räume mit Licht zu gestalten. Die Leuchte eignet sich sowohl für den Einsatz in Geschäftsräumen als auch für den privaten Gebrauch. Sie beleuchtet den Esstisch ebenso perfekt wie das Büro in einem öffentlichen Raum. Mit einer Vielzahl von Variationen kann der Benutzer die Leuchte leicht an seine Bedürfnisse anpassen.

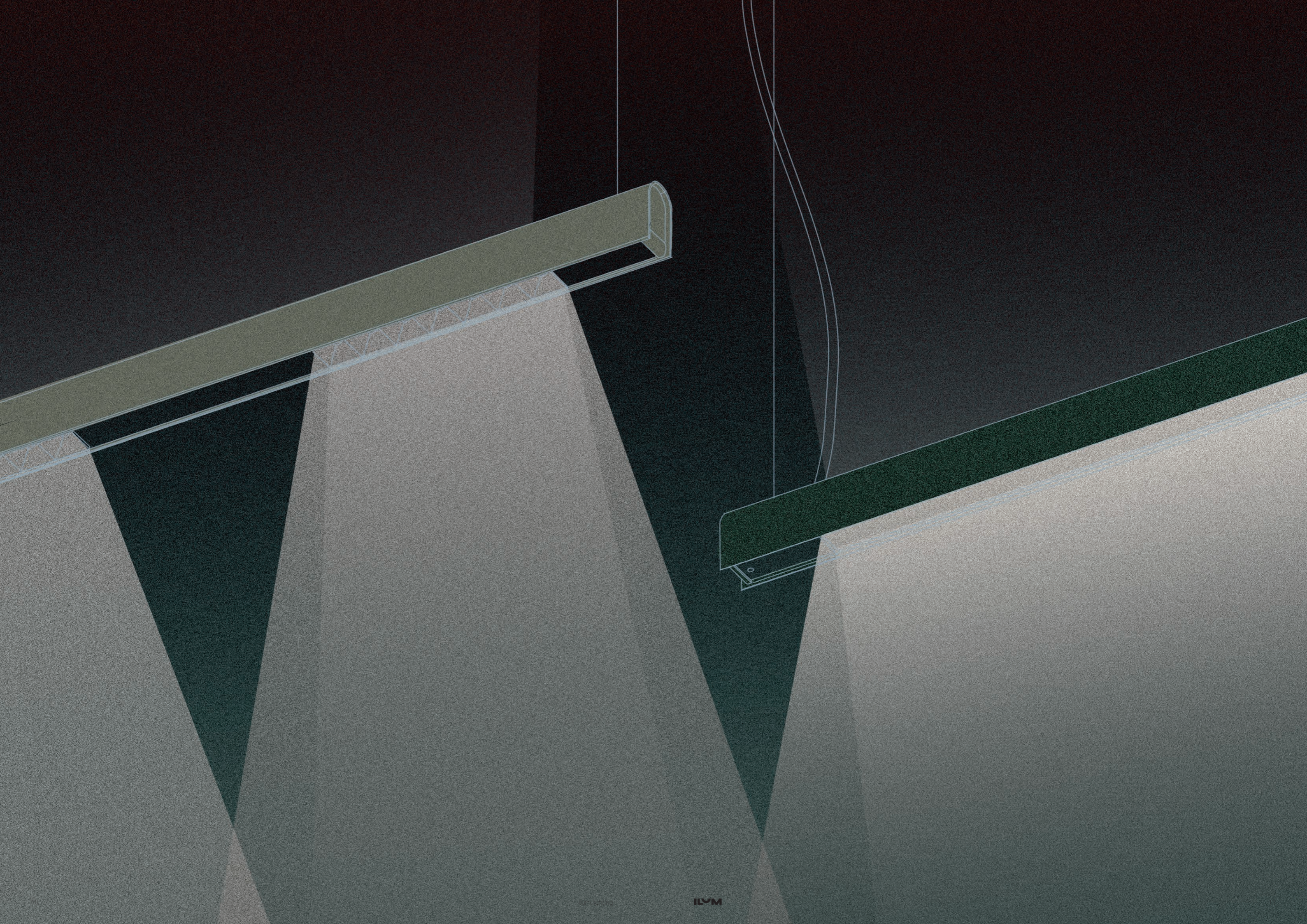

Kamerton

Your light

The ability to choose different light modules in a lamp, which alters its character, provides versatile lighting options. Whether selecting warm, soothing hues for a cozy ambiance or bright, vibrant colors for a lively atmosphere, the customizable lighting modules cater to various moods and settings, making the lamp a perfect companion for any space.



Kamerton also comes in a wall-mounted version with a swivel feature, allowing you to gently rotate and direct the light.

Kamerton 1600 S Louver



Kamerton 1100 S Line





Kamerton 800 W Line

Inspirujący dodatek

Kinkiet to elementarna część rodziny, która pozwoli ci w pełni wykorzystać dostępną przestrzeń. Światło jest emitowane zarówno w górę, jak i w dół, co zapewnia zarówno efekt dekoracyjny na ścianie, jak i funkcjonalne oświetlenie podłogi. Delikatny kształt oprawy sprawi, że stanie się ona komplementarnym elementem wnętrza. Idealnie sprawdzi się jako oświetlenie do podkreślenia dzieł sztuki lub jako akcent dodający wyrafinowania w przestrzeni korytarza czy poczekalni.

Inspiring addition

The wall sconce is an essential part of the family that allows you to fully utilize the available space. Light is emitted both upwards and downwards, providing both a decorative effect on the wall and functional floor lighting. The subtle shape of the fixture will make it a complementary element of the interior. It is perfect as lighting to highlight works of art or as an accent adding sophistication in corridor spaces or waiting rooms.

Inspirierende Ergänzung

Die Wandleuchte ist ein weiterer Bestandteil der Produktfamilie, der es Ihnen ermöglicht, den verfügbaren Platz optimal zu nutzen. Das Licht wird sowohl nach oben als auch nach unten abgestrahlt und sorgt so für einen dekorativen Effekt an der Wand und auch für eine funktionale Bodenbeleuchtung. Ihre dezente Form macht die Leuchte zu einem ergänzenden Element der Inneneinrichtung. Sie eignet sich auch ideal um Kunstwerke hervorzuheben oder als Akzent, der in Fluren oder Wartebereichen eine raffinierte Atmosphäre schafft.

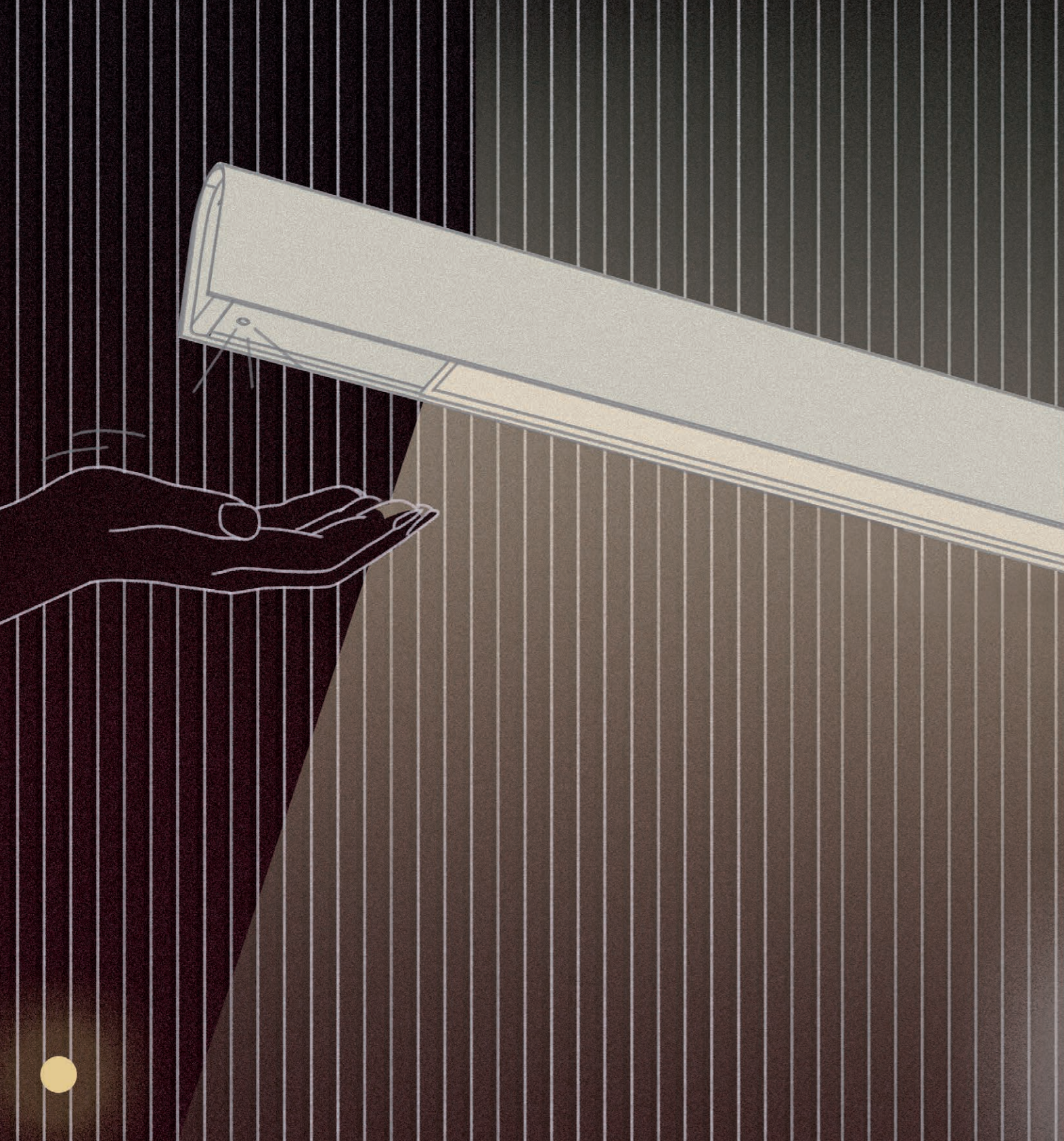

DIM TO WARM

Przyglądając się naszym własnym preferencjom zauważyliśmy, że generalnie oczekujemy od oświetlenia dwóch funkcjonalności: mocnego, jasnego, naturalnego światła na czas aktywności, oraz przyciemnionego, delikatnego i ciepłego światła na czas relaksu i regeneracji. Dlatego wprowadziliśmy funkcję bezdotykowej regulacji światła „dim to warm”, które łączy funkcję ściemniania światła za pomocą gestu, połączonego ze zmianą jego temperatury. Jednym ruchem ręki możemy ustawić optymalne dla nas na dany moment światło – od jasnego i chłodnego, do przyciemnionego i ciepłego.

DIM TO WARM

Looking at our own preferences, we noticed that in general we expect two functionalities from lighting: strong, bright, natural light for the activity time, and dimmed, soft and warm light for relaxation and recovery time. That's why we introduced the "dim to warm" touchless light control function, which combines the function of dimming the light combined with the shift of its temperature. With a simple gesture, we can set the optimum light for the moment - from bright and cool, to dim and warm.

DIM TO WARM

Bei der Betrachtung unserer eigenen Vorlieben haben wir festgestellt, dass wir im Allgemeinen zwei Funktionen von der Beleuchtung erwarten: starkes, helles, natürliches Licht für die Zeit der Aktivität und gedämpftes, weiches und warmes Licht für die Zeit der Entspannung und Erholung. Aus diesem Grund haben wir die berührungslose Lichtsteuerungsfunktion "dim to warm" eingeführt, die die Funktion des Dimmens des Lichts mit der Änderung seiner Temperatur kombiniert. Mit einer einfachen Handbewegung können wir das optimale Licht für den jeweiligen Moment einstellen - von hell und kühl bis zu gedämpft und warm.

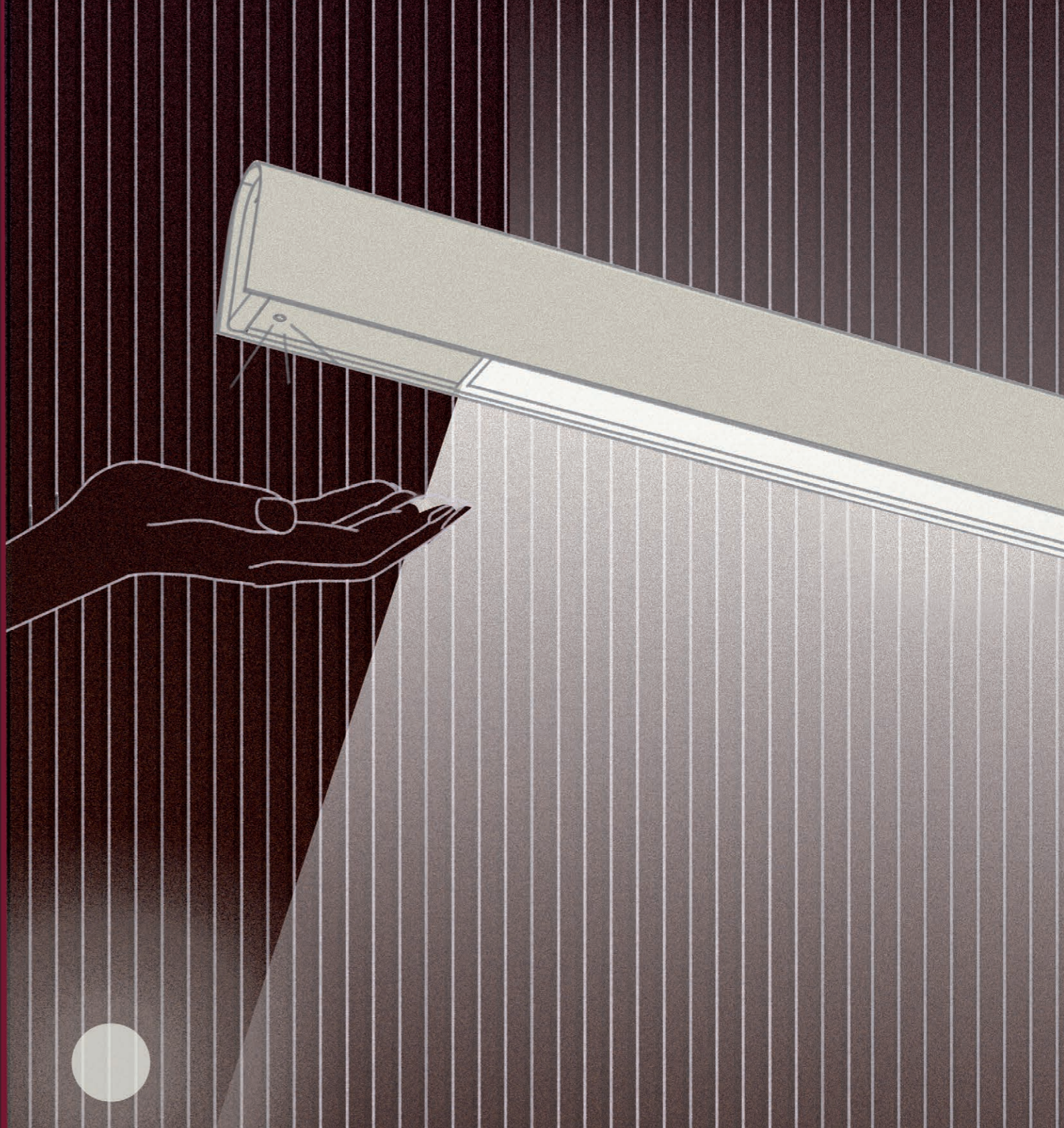

Touchless Control DIM TO WARM

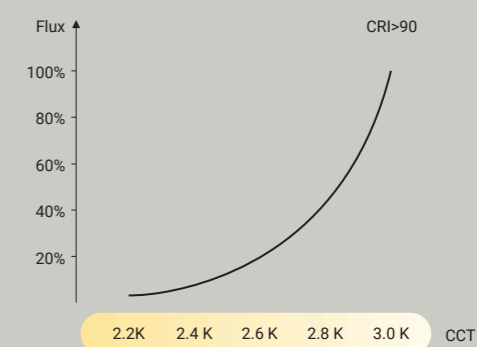
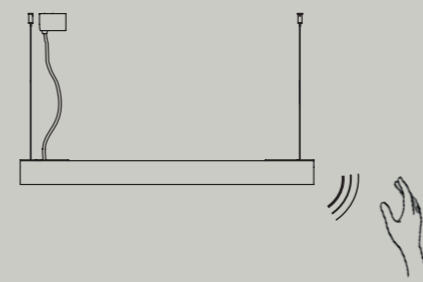

Kamerton

Collection



Kamerton
1100 S Louver

Kamerton
1600 S Louver

Kamerton
2200 S Louver

Kamerton
1100 S Line

Kamerton
1600 S Line

Kamerton
2200 S Line

↓ Suspension L 1500 / 3000 mm

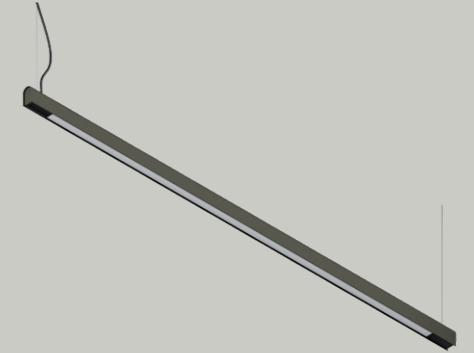
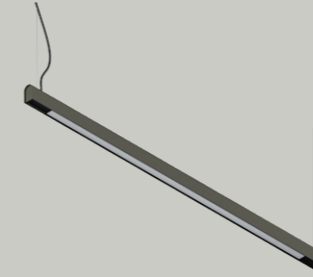
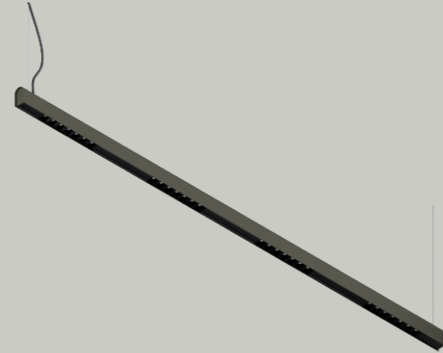
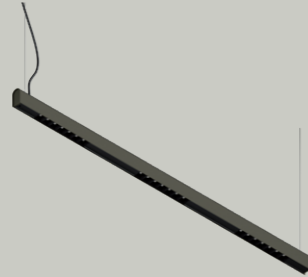

Parameters

Dimensions (LxWxH)	1077 x 44 x 76 mm	1637 x 44 x 76 mm	2197 x 44 x 76 mm
Power	29 W	45 W	61 W
Luminous flux* (direct)	up to 2292 lm	up to 3438 lm	up to 4584 lm
Luminous flux* (indirect)	up to 1227 lm	up to 2045 lm	up to 2863 lm
Optic / Diffuser	louver with lens	louver with lens	louver with lens
Control	ON-OFF, DALI, CASAMBI, DIM TO WARM	ON-OFF, DALI, CASAMBI, DIM TO WARM	ON-OFF, DALI, CASAMBI, DIM TO WARM

* Fixture lumen output data refer to 3000K.

Features

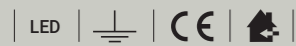

Light source: 2200-3000K, 3000K, 4000K, CRI> 90
MacAdam ≤ 3, 50.000h L80B10

Housing: extruded aluminium profile, powder coated.

Supply: 220-240 V, 50-60 Hz

IP protection: 20

Dimensions (LxWxH)	1077 x 44 x 76 mm	1637 x 44 x 76 mm	2197 x 44 x 76 mm
Power	30 W	50 W	70 W
Luminous flux* (direct)	up to 2457 lm	up to 4095 lm	up to 5733 lm
Luminous flux* (indirect)	up to 1227 lm	up to 2045 lm	up to 2863 lm
Optic / Diffuser	satine linear optic, dark microcrystal	satine linear optic, dark microcrystal	satine linear optic, dark microcrystal
Control	ON-OFF, DALI, CASAMBI, DIM TO WARM	ON-OFF, DALI, CASAMBI, DIM TO WARM	ON-OFF, DALI, CASAMBI, DIM TO WARM

For the latest product data please refer to the web page. To order a fixture, use the online product configurator.

Colors

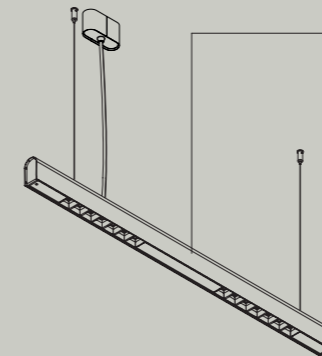

Housing colors:

Basic

- white (RAL9016)
- fog (RAL7038)
- graphite (RAL7024)
- black (RAL9005)

Standard

- saphire (RAL 5003)
- forrest (RAL 6005)
- wine (RAL 3005)
- ochra

Premium

- sandy
- earth
- sage
- cloudy
- night
- black dust
- volcano
- marrone

Kamerton

Collection



Kamerton
800 W Line

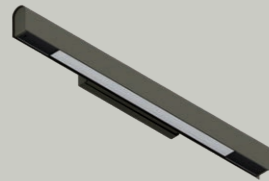

Kamerton
1100 W Line

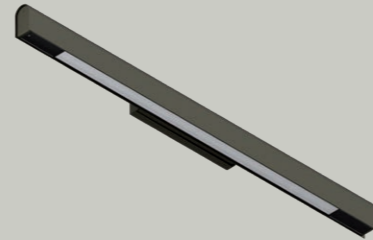

Parameters

Dimensions (LxWxH)	797 x 81 x 76 mm	1077 x 81 x 76 mm
Power	20 W	30 W
Luminous flux* (direct)	up to 1638 lm	up to 2457 lm
Luminous flux* (indirect)	up to 818 lm	up to 1227 lm
Diffuser	satine linear optic, dark microcrystal	satine linear optic, dark microcrystal
Control	ON-OFF, DALI, CASAMBI	ON-OFF, DALI, CASAMBI

* Fixture lumen output data refer to 3000K.

Features

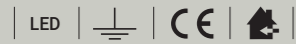

Light source: 3000K, 4000K, CRI> 90
MacAdam ≤ 3, 50.000h L80B10

Housing: extruded aluminium profile, powder coated.

Supply: 220-240 V, 50-60 Hz

IP protection: 20

Kamerton
Stand Louver



Kamerton
Stand Line



Parameters

Dimensions (LxWxH)	1235 x 2100 mm	1235 x 2100 mm
Power	29 W	30 W
Luminous flux* (direct)	up to 2292 lm	up to 2457 lm
Luminous flux* (indirect)	up to 1227 lm	up to 1227 lm
Diffuser	louver with lens	satine linear optic, dark microcrystal
Control	ON-OFF, CASAMBI, DIM TO WARM	ON-OFF, CASAMBI, DIM TO WARM

* Fixture lumen output data refer to 3000K.

Features

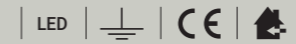

Light source: 2200-3000K, 3000K, 4000K, CRI> 90,
MacAdam ≤ 3, 50.000h L80B10

Housing: extruded aluminium profile, powder coated.

Supply: 220-240 V, 50-60 Hz

IP protection: 20



ILUM

ul. 1 Maja 46a
05-555 Tarczyn, Poland
tel: +48 22 736 73 00
info@ilum.lighting

ilum.lighting



Our mission is healthy light.

We create human and environment – friendly solutions: natural, comfortable to the eye, rendering genuine colours. We believe in timeless and universal aesthetics. We design lamps that are minimalist in their form, and which can complement both traditional and modern architecture. To draw up custom designs, we approach each interior from a fresh perspective.

Quality is at the core of our work. All of our products are manufactured in our own factory in Tarczyn, with the help of a team of lighting experts – technology and product engineers. For 20 years, we have completed a plethora of projects, and each of them represents how we understand the culture of light and the way light can be experienced in space. When considering the role of light in contemporary architecture, one cannot disregard the history of Bauhaus. The school, or rather a free, creative collective Light was of the building blocks of architecture in Modernism. In those times, as a result of technological progress electric light became just as important building material as concrete or steel. Shaping the experience of space through artificial light in buildings was an entirely new challenge for Bauhaus architects and designers. Their avant-garde approach to materials and forms, combined with the consolidation of modernist standards in terms of aesthetics and form in the middle of the 20th century, became the foundation for contemporary design.

Today, when looking at Infinite numbers of light fixtures and lamps, it is easy to forget that today's lighting culture has its roots in the school of Bauhaus and owe sit its shape.

